

**Handbook for
eSIGN
with IO-Link
V 1.0 - 2021**



Handbook eSIGN with IO-Link

Content

- 1 Introduction 21
 - 1.1 What is IO-Link?21
 - 1.2 System Overview21
- 2 Initial Set up 22
 - 2.1 Electrical connection22
 - 2.1.1 Connection.....22
 - 2.1.2 Overview: Electrical Connection of the Signal Devices23
 - 2.2 Status LED23
 - 2.3 Import of the IODD24
 - 2.4 Communication parameters.....24
- 3 eSIGN Functional Description..... 25
 - 3.1 Operating modes of the eSIGN.....25
 - 3.2 Basic functions25
 - 3.2.1 Optical Parameters:.....26
 - 3.2.2 Audible Parameters:26
 - 3.2.3 Global Parameters27
 - 3.2.4 Reset Function of the eSIGN.....27
 - 3.3 Control of the Signal Tower28
 - 3.3.1 Control in Signal Tower Mode28
 - 3.3.2 Control in Autoscale Mode29
 - 3.3.3 Control in Filling Level Mode30
 - 3.3.4 Control in Individual Mode31
 - 3.3.5 Control of the Siren Functions32
 - 3.4 Configuration of the eSIGN via Index Parametrisation35

1 Introduction

1.1 What is IO-Link?

IO-Link is a globally standardized I/O technology, IEC61131-9, for the communication between controller and sensor/actuator below the fieldbus level.

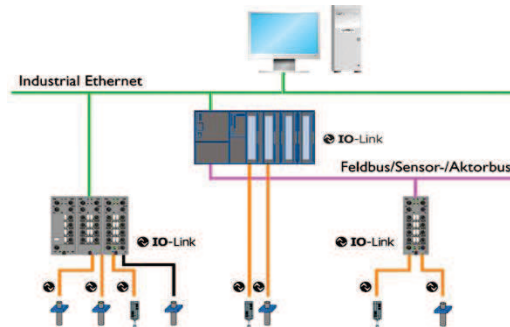

The standard connection technology, with unshielded M12 cables is used. The 3-conductor connection of a digital switching signal is expanded to include bi-directional communication. Parameter and configuration data are written to the sensor/actuator from the controller and process and diagnostic data are read from the sensor/actuator to the controller. IO-Link is not a fieldbus, but rather a point-to-point connection for any IO-Link devices such as sensors, actuators and signal devices. Due to the fact that all operation parameters are saved in the device and can be read by the master, complex parameterization of the devices is no longer required.

1.2 System Overview

IO-Link consists of the following components:

- IO-Link master
- IO-Link devices (e.g. sensors, valves, I/O modules, signal devices)
- Unshielded standard cable
- Engineering tools for project planning and parameter setting of the IO-Link

The IO-Link master creates the connection between the IO-Link devices and the automation system. As a component of the distributed system, the IO-Link master is installed directly in the field, either in the switch cupboard or as remote I/O with protection class IP65/67. The IO-Link master communicates via various fieldbuses or product-specific backboard buses. An IO-Link master can have multiple IO-Link ports (channels). One IO-Link device can be connected to each port (point-to-point communication). This means that IO-Link is point-to-point communication, not a fieldbus. The power supply of the device also occurs via the output sockets or terminals of the IO-Link master.

Further information about IO-Link and the IO-Link system description can be found at www.io-link.com.

2 Initial Set up

2.1 Electrical connection

In general IO-Link masters have 5 pin sockets.

There are two different types of connections to the IO-Link master (ports):

Port Class A (Type A)

With this type the functions of Pins 2 and 5 are not fixed. The manufacturer defines these functions. Normally Pin 2 is occupied with an additional digital channel.

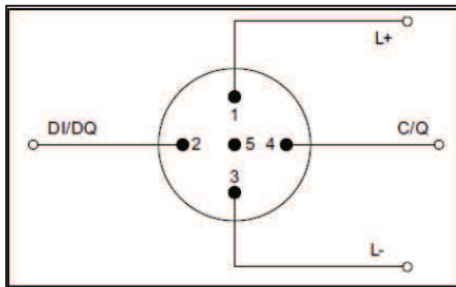

Port Class B (Type B)

This type offers an additional power supply voltage and is suitable for the connection of devices which have high electricity demands. This means that an additional (electrically isolated) power supply voltage is available via Pins 2 and 5. A 5-conductor standard cable is needed for this additional power supply voltage.

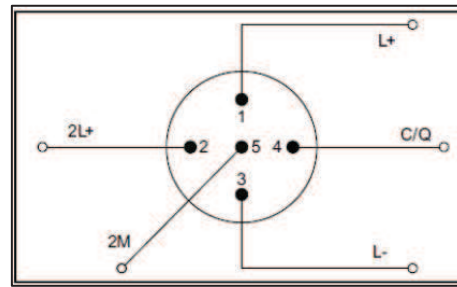

2.1.1 Connection

The connection is made via a 4 conductor connector with the following pin assignment:

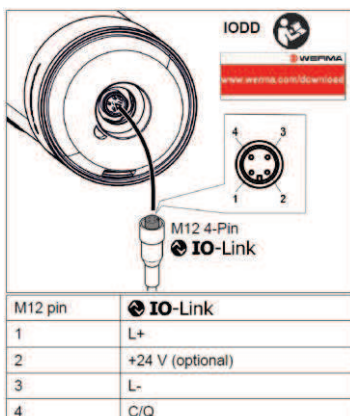

Part numbers:

657.010.55 - 9 Segments

657.110.55 - 9 Segments with siren

657.510.55 - 15 Segments

657.610.55 - 15 Segments with siren

2.1.2 Overview: Electrical Connection of the Signal Devices

IO-Link Standard			Terminal
M12 Pin assignment	Wire colour M12 Cable (IEC 60947-5-2)	IO-Link Function	eSIGN
1	brown	L+	2
2	white	2L+	3
3	blue	L-	0
4	black	C/Q	1

IO-Link Type/Class A: Some IO-Link masters with current consumption > 200 mA need external auxiliary voltage (2L+).

2.2 Status LED

The functional status of the signal tower is displayed via two LEDs. The status LEDs are located in the base of the signal tower.

The two colours convey the following information:

- Red: The power supply is on; no IO-Link communication.
- Green: The power supply is on; IO-Link communication is working.
- Yellow: Firmware-Update is running

If no LED is active, please check the power supply and the connection cable.

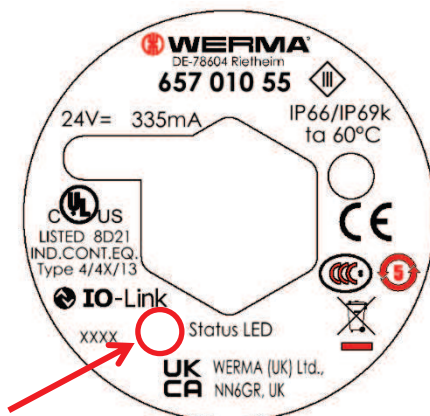

The status LED can be found inside the base behind the type label.

2.3 Import of the IODD

All functions of the device that are relevant for the machine control are described in a standardized device description file (IODD **IO-Link Device Definition**). This IODD is available on the manufacturer homepage at <https://www.werma.com/de/support/downloads.php> as well as at <https://ioddfinder.io-link.com>.

After importing the IODD to the controller, search for new devices. The eSIGN signal tower should automatically be recognized.

The approach used to import the IODD and search for devices depends on the controller manufacturer. More information can be found in the manufacturer's documentation.

2.4 Communication parameters

The following communication parameters are used:

IO-Link Revision	V1.1
Bitrate	COM3 230,4 kBit/s
Min. Cycle Time	6ms
SIO Mode	No
Block parametrisation	Yes
Data Storage	Yes

If there are communication problems, please check the settings and correct them as required.

3 eSIGN Functional Description

3.1 Operating modes of the eSIGN

The eSIGN has four operating modes:

- Signal Tower Mode
- Autoscale Mode
- Filling Level Mode
- Individual Mode

The operating modes can only be selected individually and cannot be combined. Setting of the operating mode occurs via the "Operating Mode" parameter.

Parameter	Value	Description
Operating Mode	0	Signal Tower Mode
	1	Autoscale Mode
	2	Filling Level Mode
	3	Individual Mode

3.2 Basic functions

The following parameters are used for every operating mode.

When using the parameters the following settings can be applied for each segment of the eSIGN:

- Colour
- Light effect
- Brightness

The detailed possibilities to configure the settings are shown in the table "Parameters for Optical Functions" below. In this way the possibility of an individual colour selection for each segment and the selection of the light effect is enabled because these can also be combined with each other.

This results in a bit number of 24 Bit (16 Bit for the versions without the siren and 24 Bit for versions with the siren).

3.2.1 Optical Parameters:

Parameter	Value	Description
Lighteffect Segment n	0	Continuous
	1	Blinking 3Hz
	2	Blinking 2Hz
	3	Blinking 1Hz
	4	Flashing (1x)
	5	Flashing (2x)
	6	Flashing (3x)
	7	Rotating
Quotient R	0..255	Quotient R
Quotient G	0..255	Quotient G
Quotient B	0..255	Quotient B
Brightness Segment n	0	Minimum
	1	Low
	2	High
	3	Maximum
Default Colour	0	Individual PWM
	1	Red
	2	Green
	3	Blue
	4	Yellow
	5	Light Yellow
	6	Turquoise
	7	Violet
8	White	

3.2.2 Audible Parameters:

Parameter	Value	Description
Tone type	0	Sound off
	1	Permanent
	2	Pulse
	3	Rising
	4	Falling
	5	Alternating
	6	Sweep
Frequency 1 (Start)	245..6000	Frequency at the start of a cycle in Hz
Frequency 1 (Stop)	0 (Mode 1) 245..6000 (Mode 2..6)	Frequency at the end of a cycle in Hz
Frequency 3 (period)	0 (Mode 1) 1..10000 (Mode 2..6)	Frequency for time between frequency 1 and frequency 2 in Hz*10

Volume	0	Low
	1	Medium
	2	Loud
	3	Very loud
Repeat count	0..65535	Repeat count
Pause after repeat	0..65535	Pause after repeat
Pause between cycles	0..65535	Duration of the pause between cycle in ms
Hold time Frequency 2	0..65535	Setting of the Hold time for Frequency 2 in ms

3.2.3 Global Parameters

Parameter	Value	Description
Power Reduction	0	Power Reduction (Current Consumption) OFF
	1	Power Reduction (Current Consumption) ON. Corresponds to a current consumption of c. 200mA
Installation position	0	Normal (Base at bottom of tower)
	1	Upside down
User Text	Text with max. 232 characters	Free text for user

3.2.4 Reset Function of the eSIGN

The command "Reset Factory Settings" deletes the existing parameterisation and resets it to the default factory setting.

The delivery state is "Autoscale Mode":

- With 3 tiers (RD/YE/GN) for the variant with 9 segments
- With 5 tiers (RD/YE/GN/BU/CL) for the variant with 15 segments

Power reduction (current consumption) is ON. The activation of the power reduction is to limit the current consumption from the master during the initial set up. We refer here to the note on IO-Link type/class A and the possible need for an external auxiliary voltage under Section 2.2 "Electrical connection". After the power reduction has been cancelled, the LEDs are set to continuous light with 100% brightness.

3.3 Control of the Signal Tower

3.3.1 Control in Signal Tower Mode

Individual eSIGN segments (for example 3) can be combined to create a signal tower tier. This enables a classic signal tower to be created in an electronically modular form.

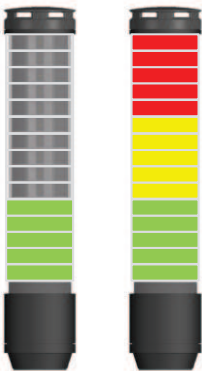

In this mode the tiers have fixed positions and can be off if the corresponding tier and optical signal is not triggered. This mode limits the illuminated surface of the signal within the signal tower to a certain area.

The number of tiers is limited to a maximum of 3 (9 segment version) or 5 (15 segment version).

The following table shows the process data in this operating mode:

Byte	1								0								
Bit	7	6	5	4	3	2	1	0	7	6	5	4	3	2	1	0	
Beschreibung													Segment 5	Segment 4	Segment 3	Segment 2	Segment 1

When forming tiers, up to 8 segments can be combined. Up to 5 signal tiers can be used.

According to the number of tiers set, process data bits starting at segment 1 are used.

Example process data can be seen in the following table:

Process data		Configurable tiers				
		1	2	3	4	5
Byte 0	Bit 0	Tier 1	Tier 1	Tier 1	Tier 1	Tier 1
	Bit 1		Tier 2	Tier 2	Tier 2	Tier 2
	Bit 2			Tier 3	Tier 3	Tier 3
	Bit 3				Tier 4	Tier 4
	Bit 4					Tier 5
	Bit 5					

3.3.2 Control in Autoscale Mode

This is the standard operating mode for the default factory setting.

eSIGN segments are automatically divided equally between the number of triggered pins and status warnings. This enables the full potential of the eSIGN to be exploited by providing full-surface illumination. If for example only one status warning is active then the entire surface of the eSIGN is illuminated in one colour for maximum visibility.

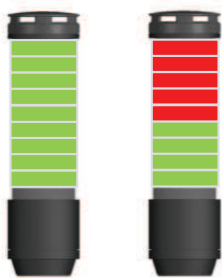

If several status warnings are active, the illuminated area is split proportionally. If the segments cannot be divided equally then the highest priority colour receives the remaining segment(s).

The following table shows the process data in this operating mode:

Byte	1								0							
	7	6	5	4	3	2	1	0	7	6	5	4	3	2	1	0
Beschreibung												Segment 5	Segment 4	Segment 3	Segment 2	Segment 1

In this mode the process data is reduced to 5 Bit.

The parameters of tiers 1 to 5 are used for configuration.

The following table shows an example of the process data:

Process data		Autoscale Mode
Byte 0	Bit 0	Segment 1
	Bit 1	Segment 2
	Bit 2	Segment 3
	Bit 3	Segment 4
	Bit 4	Segment 5

3.3.3 Control in Filling Level Mode

In this operating mode, an analog value is represented through the segments of the eSIGN.

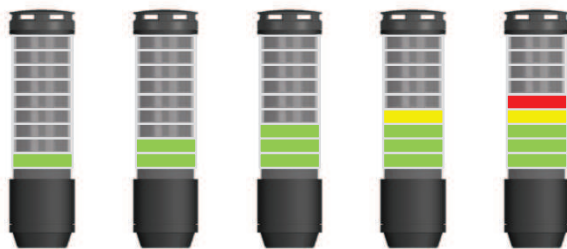

eSIGN segments are used as a filling level indicator ranging from 0% when all segments are off to 100% when all segments are activated. This enables precise signalisation of job progress or material availability in machine processes by slowly illuminating the signal tower from bottom to top or top to bottom.

8 Bit of process data are processed here. The possible range of values is from 0 to 100.

Byte	Byte 0	
Value	0..100	%-Value

To set up the signal tower the parameters from segments 1 to 15 are used.

Exemplary process data for can be found in the following table:

Process data		Filling level mode
Byte 0	Bit 0	A
	Bit 1	N
	Bit 2	A
	Bit 3	L
	Bit 4	O
	Bit 5	G
	Bit 6	Value (0...100%)
	Bit 7	
Byte 1	Bit 0	

3.3.4 Control in Individual Mode

In this operating mode, each segment is mapped to a certain switching signal.



Every eSIGN segment (9 or 15 per tower) can be set und triggered completely individually to enable a maximum of customised signalling options.

This functionality results in 15 bits for the process data. The process data of this operating mode is shown below:

Byte	1								0							
Bit	7	6	5	4	3	2	1	0	7	6	5	4	3	2	1	0
Description	.	Segment 15	Segment 14	Segment 13	Segment 12	Segment 11	Segment 10	Segment 9	Segment 8	Segment 7	Segment 6	Segment 5	Segment 4	Segment 3	Segment 2	Segment 1





Exemplary process data is shown in the following table:



Process data		Individual Mode
Byte 0	Bit 0	Segment 1
	Bit 1	Segment 2
	Bit 2	Segment 3
	Bit 3	Segment 4
	Bit 4	Segment 5
	Bit 5	Segment 6
	Bit 6	Segment 7
	Bit 7	Segment 8
Byte 1	Bit 0	Segment 9
	Bit 1	Segment 10
	Bit 2	Segment 11
	Bit 3	Segment 12
	Bit 4	Segment 13
	Bit 5	Segment 14
	Bit 6	Segment 15
	Bit 7	

3.3.5 Control of the Siren Functions

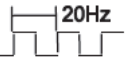
For the siren 1 bit of process data is used. Numeric values from 1 to 10 are possible. These correspond directly to the tones 1 to 10 and are used to control the respective tone.

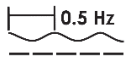
The pre-assigned tones can be found in the following table:

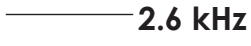
Tone	Frequency	Description	Max. dB (A)
1	 2.8 kHz [*]	Continuous tone	104
2	 0.9 kHz	Continuous tone	96
3	 2.8 kHz	Pulse tone	97
4	 0.9 kHz	Pulse tone	93
5	 2.8 kHz	Pulse tone	103
6	 0.9 kHz	Pulse tone	96
7	 2.8 kHz	Pulse tone	104
8	 2.3 kHz- 3.6 kHz	Sweep tone	104

9		Continuous tone	105
10		Alternating tone	92

Alternatively, individual tones can be configured. The parameters described in Section 3.2.2 are used for this option.

First, the tone type must be selected. The following tone types are available:

- Continuous tone
- Pulse tone
- Rising tone
- Falling tone
- Alternating tone
- Sweep tone

The following diagram shows the respective effects of the parameters.

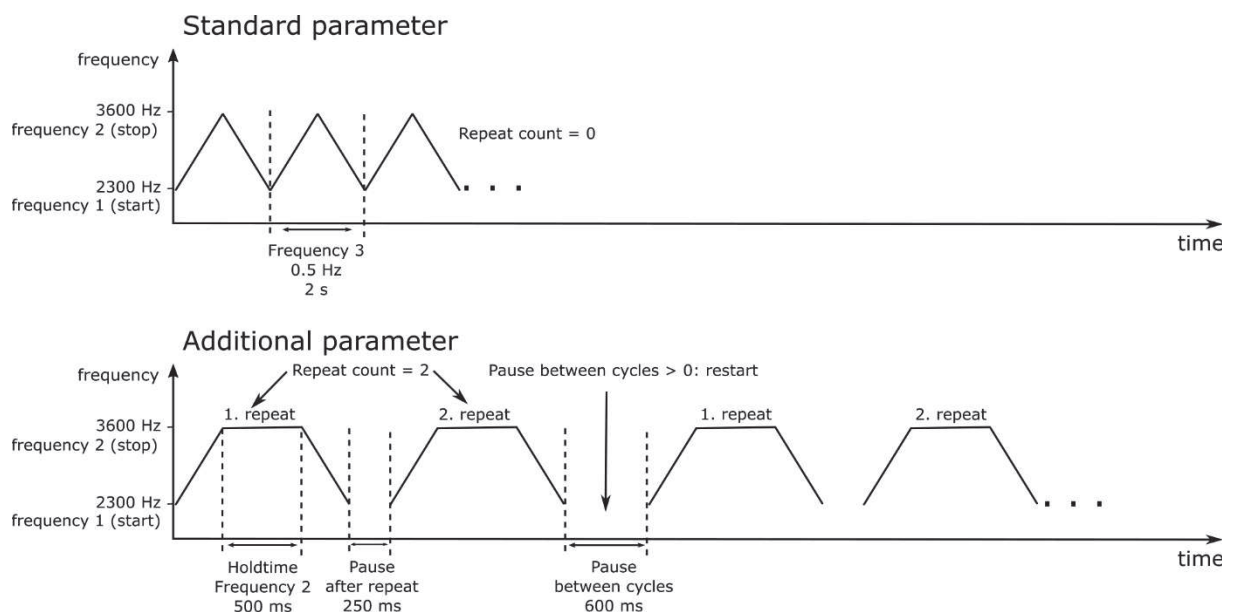

Example from the IODD:

Tone 8.Tone type	rw	Sweep	▼
Tone 8.Frequency 1 (start)	rw	2300	
Tone 8.Frequency 2 (stop)	rw	3600	
Tone 8.Frequency 3 (period)	rw	5	
Tone 8.Volume	rw	Low	▼
Tone 8.Repeat count	rw	0	
Tone 8.Pause after repeat	rw	0	
Tone 8.Pause between cycles	rw	0	
Tone 8.Holdtime Frequency 2	rw	0	

3.4 Configuration of the eSIGN via Index Parametrisation

Description of the Parameters

Index	Sub-index	Parameter	Access	Byte Length	Value	Description
02		System command	wo	1	130	Reset Factory settings
16		Vendor Name	ro	48		WERMA Signaltechnik GmbH + Co. KG
17		Vendor Text	ro	48		www.werma.com
18		Product Name	ro	32		eSIGN IO-Link n Segments (with Siren)
19		Product ID	ro	16		657.xxx.xx
20		Product Text	ro	64		eSIGN IO-Link n Segments (with Siren)
21		Serial Number	ro	16		Format: 0000000000000000
22		Hardware Revision	ro	16		Format: 1.0
23		Firmware Version	ro	16		Format: 1.0.0
24		Application Text	rw	32		
25		FunctionTag	rw	32		
26		FunctionTag	rw	32		
36		Device Status	ro			
37		Detailed Device Status	ro			
74		OperatingHours	ro	4		
100		Operating Mode	rw	1		
101-115	1	Appearance	rw	1		
	2	PWM R	rw	1		
	3	PWM G	rw	1		
	4	PWM B	rw	1		
	5	Brightness	rw	1		
	6	Default Colour	rw	1		
	7	not used	rw	1		
	8	Priority	rw	1		
120-130	1	Mode	rw	1		
	2	Frequency 1	rw	2		
	3	Frequency 2	rw	2		
	4	Frequency 3	rw	2		
	5	Volume	rw	1		
	6	Repeat	rw	2		
	7	Repeat Pause	rw	2		
	8	Cycle Pause	rw	2		
	9	Hold Time	rw	2		
131		PowerReduction	rw	1		
132		Filling Level Mode	rw	1		
138		Overheadmount	rw	1		
139		TierCount	rw	1		



WERMA Signaltechnik GmbH + Co.KG

D-78604 Rietheim-Weilheim

Phone: +49 (0)7424 / 9557-222

Fax: +49 (0)7424 / 9557-44

support@werma.com

www.werma.com

WERMA reserves the right to make technical improvements to the product and accepts no responsibility for mistakes or printing errors which may be contained in this documentation.